



Our Product :

Fire Tube Boiler

Water Tube Boiler

Thermal Oil Heater

Hot Water Boiler

FIRETUBE STEAM BOILER - IDM-FT500 to IDM-FT8T

Firetube Steam Boiler Model: IDM-FT

Winskettel is a legendary boiler brand in Indonesia that was founded by Ir. Gunawan, many steam boilers have been produced and have spread throughout Indonesia. One of its superior products is firetube type boiler with Gas fuel (LPG, CNG, PGN) and Light Oil.

At present, PT Indira Dwi Mitra (PT IDM) is present in partnership with Winskettel boiler into a joint team to realize superior Firetube Boiler products supported by modern technology for the industrial market in Indonesia. In this collaboration PT IDM will serve Firetube Steam Boiler fabrication which has a capacity ranging from 500kg to 10Ton / h with a working pressure of up to 20barg.



WINSKETTEL
THE BOILER MAKER



Advantages of IDM-FT

- Easier access and lower maintenance cost.
- Three passes economic design.
- High heating surface.
- Lower metal temperature effect lower heat losses and cooler boiler room.
- Eliminate refractories, insulator and baffles.
- Increased radiant surface and bigger furnace diameter.
- Conformity with Rules, Standards and Regulations.
- Constructed and factory tested under a total Quality Management System.
- High quality fittings and components.
- Full year warranty provided by qualified after sales service.
- Large shell diameter and water line to dry steam production and large reserve.

Data for Burner Determination Boiler Model: IDM-FT

Steam output kg/h	Heat output KW	Burner Input kW	Length of flame tube w.o. rear reversing chamber mm	Length of rear reversing chamber mm	Inner flame tube diameter mm	Draught loss mbar
500	326	364	1400	350	576	5,8
800	522	583	1400	350	576	7,3
1000	652	728	1700	350	626	5,9
1250	815	910	1700	350	626	6,2
1600	1043	1165	1920	350	722	8,5
2000	1304	1457	2170	350	722	11,0
2500	1630	1820	2420	350	722	11,0
3200	2090	2335	2750	500	780	10,0
4000	2608	2914	3250	500	864	11,2
5000	3260	3640	3740	500	864	13,2
6000	3910	4369	4400	500	874	12,0
8000	5216	5828	4640	600	1060	14,1

FIRETUBE STEAM BOILER - IDM-FT500 to IDM-FT8T

Boiler Dimension Three Pass Boiler Model: IDM-FT



WINSKETEL
THE BOILER MAKER

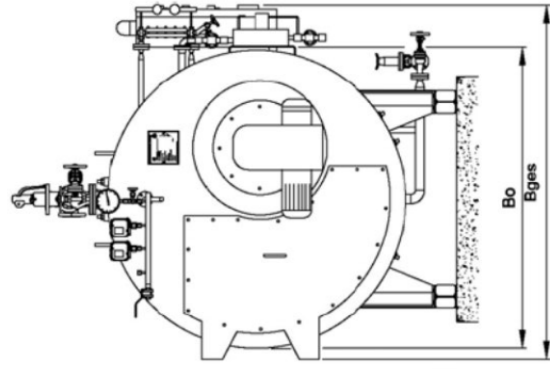

FRONT VIEW

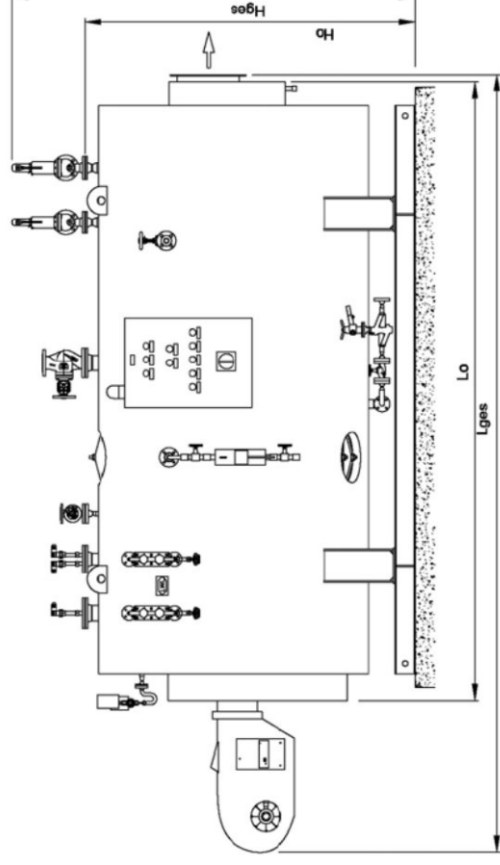

SIDE VIEW

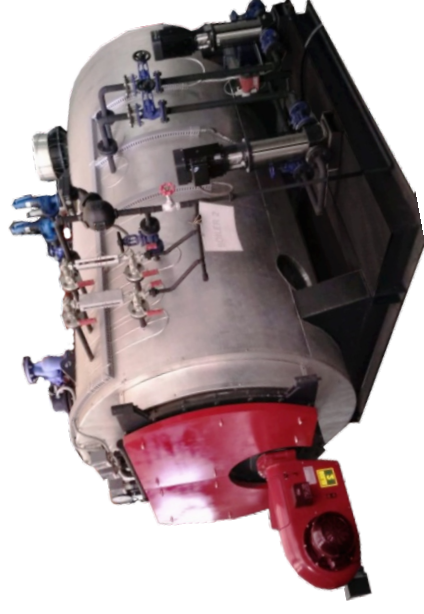

Size	Steam output	Heat output	Water Content	Transport weight	Operating weight	H _{ges}	H _o	L _{ges}	L _o	B _{ges}	B _o
500	0,5 t/h	0,33 MW	0,9 m ³	2,3 t	3,6 t	1975 mm	1590 mm	3230 mm	2720 mm	1600 mm	1450 mm
800	0,8 t/h	0,52 MW	1,1 m ³	2,6 t	4,2 t	2125 mm	1740 mm	3230 mm	2720 mm	1750 mm	1600 mm
1000	1,0 t/h	0,65 MW	1,4 m ³	3,8 t	5,8 t	2285 mm	1900 mm	3600 mm	3020 mm	1860 mm	1710 mm
1250	1,25 t/h	0,82 MW	1,4 m ³	4,5 t	6,5 t	2285 mm	1900 mm	3700 mm	3020 mm	1860 mm	1710 mm
1600	1,6 t/h	1,05 MW	2,4 m ³	4,6 t	7,8 t	2535 mm	2090 mm	3700 mm	3220 mm	2050 mm	1900 mm
2000	2,0 t/h	1,31 MW	2,4 m ³	5,3 t	8,6 t	2535 mm	2090 mm	3900 mm	3480 mm	2050 mm	1900 mm
2500	2,5 t/h	1,63 MW	2,6 m ³	5,4 t	8,9 t	2620 mm	2090 mm	4600 mm	3730 mm	2050 mm	1900 mm
3200	3,2 t/h	2,09 MW	3,1 m ³	6,6 t	10,8 t	2720 mm	2190 mm	5100 mm	4230 mm	2200 mm	2000 mm
4000	4,0 t/h	2,61 MW	4,8 m ³	8,2 t	14,4 t	2925 mm	2340 mm	5600 mm	4730 mm	2400 mm	2150 mm
5000	5,0 t/h	3,27 MW	5,2 m ³	9,5 t	16,3 t	2925 mm	2340 mm	6130 mm	5230 mm	2400 mm	2150 mm
6000	6,0 t/h	3,92 MW	8,1 m ³	11,6 t	21,8 t	3175 mm	2590 mm	6450 mm	5750 mm	2600 mm	2350 mm
8000	8,0 t/h	5,23 MW	10,6 m ³	17,7 t	32,6 t	3605 mm	2890 mm	7320 mm	6250 mm	3000 mm	2700 mm

STEAM GENERATOR - IDM300 to IDM5000

Technical Specifications - Capacity and Consumption

TECHNICAL DATASHEET								
Features	Unit	IDM 300	IDM 500	IDM 1000	IDM 1500	IDM 2000	IDM 3000	IDM 5000
Steam production	Kg/h	300	500	1000	1500	2000	3000	5000
Design pressure	bar	12	12	12	12	12	12	12
Max working pressure	bar	10	10	10	10	10	10	10
TOTAL ELECTRIC POWER								
Heavy fuel oil	KW	4,3	5,3	9,6	12,9	16,0	24,0	32
Natural gas or diesel oil	KW	2,3	2,3	4,6	5,9	7,0	12,0	18
FUEL CONSUMPTION AT 100% OF THE LOAD								
Heavy fuel oil	Kg/h	22	36	72	110	145	218	363
Natural gas	Nm ₃ /h	25	41	81.5	124.5	164	247	411
Diesel oil	kg/h	23	38	76	116	153	230	383
FUEL CALORIFIC POWER								
Heavy fuel oil	Kcal/kg	9500						
Natural gas	Kcal/Nm ₃	8400						
Diesel oil	Kcal/kg	9000						
Standard electric power data	380 V / 50 Hz / 3 phases with neutral							
Auxiliaries voltage	220 V							



Steam Generator



Thermal Oil Heater

STEAM GENERATOR - IDM300 to IDM5000

Dimensions of flash coil steam generators IDM300-5000

Vertical Design

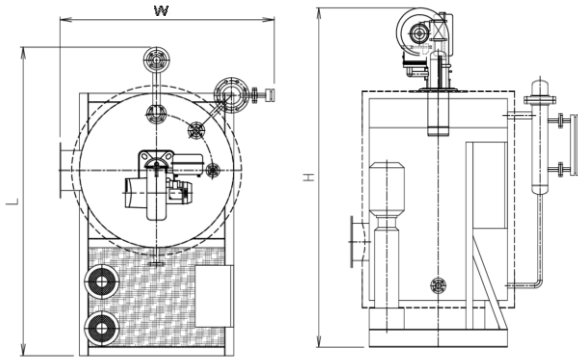

Horizontal Design

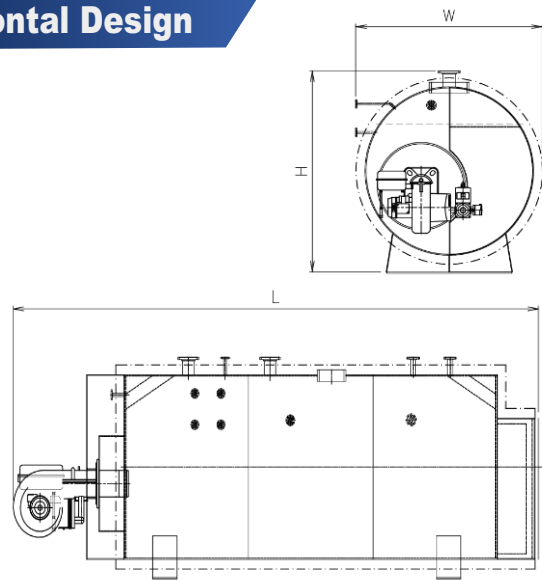

OVERALL DIMENSIONS AND CONNECTIONS OF STEAM GENERATORS IDM300-5000

MODEL		IDM 300	IDM 500	IDM 1000	IDM 1500	IDM 2000	IDM 3000	IDM 5000	
VERTICAL VERSION DIMENSIONS									
L	Length	mm	1650	1900	2200				
W	Width	mm	1080	1180	1600				
H	Height	mm	1950	2400	3050				
HORIZONTAL VERSION DIMENSIONS									
L	Length	mm			2400	2900	3550	4100	6450
W	Width	mm			1280	1400	1500	1750	2100
H	Height	mm			1650	1700	1850	2200	2260
GENERAL TECHNICAL DATA									
Stack connection	mm	250	250	320	385	385	485	485	
Steam outlet	DN	25	40	50	65	80	100	125	
	PN	16	16	16	16	16	16	16	
Safety valve	DN	20/40	20/40	20/40	25/40	25/40	40/50	50/65	
	PN	25/16	25/16	25/16	25/16	25/16	25/16	25/16	
Natural gas connection		1"G	1 1/2"G	2"G	2"G	2"G	2 1/2"G	2 1/2"G	
Feed water inlet		1"G	1"G	1"G	1"G	1 1/2"G	1 1/2"G	2"G	
Total volume	l	208	370	620/850	1100	2400	2710	3100	
Pipes diameter	mm	60.3	60.3	60.3/50.8	50.8	50.8	50.8	50.8	
Heating surface	m ²	6	8.8	14	18	32	34	34	
Empty weight	Kg	750	900	1100	2200	2800	3400	4300	

HOT WATER BOILER- IDM70 to IDM3000

Dimensions of flash coil steam generators IDM70-3000

Vertical Design

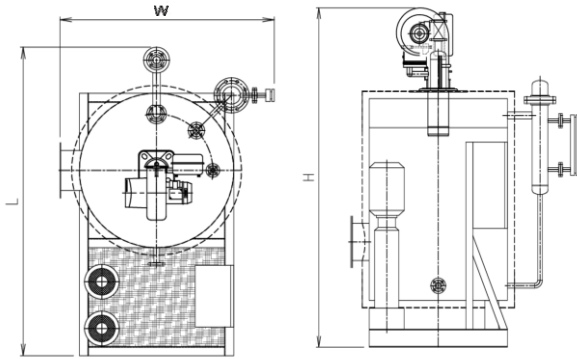

Horizontal Design

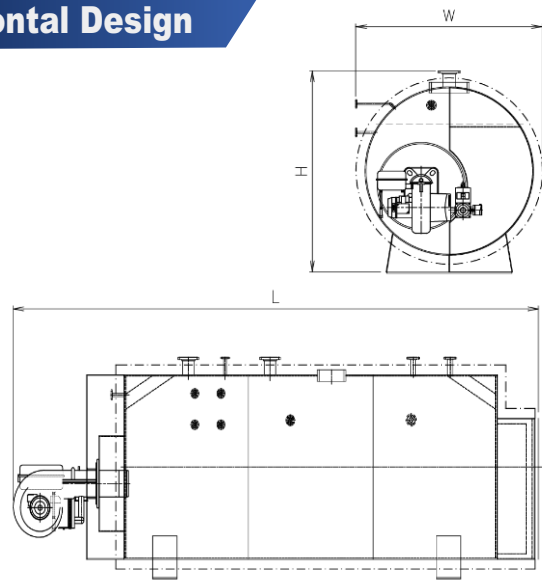

OVERALL DIMENSIONS AND CONNECTIONS OF STEAM GENERATORS IDM70-3000

MODEL			IDM 70	IDM 200	IDM 500	IDM 1000	IDM 1500	IDM 2000	IDM 3000
VERTICAL VERSION DIMENSIONS									
L	Length	mm	1350	1650	1900	2200			
W	Width	mm	900	1080	1180	1600			
H	Height	mm	1850	1950	2400	3050			
HORIZONTAL VERSION DIMENSIONS									
L	Length	mm					2400	2900	3550
W	Width	mm					1280	1400	1500
H	Height	mm					1650	1700	1850
GENERAL TECHNICAL DATA									
Stack connection	mm		250	250	250	320	320	385	385
Steam outlet	DN		25	25	40	50	50	65	80
	PN		16	16	16	16	16	16	16
Safety valve	DN		20/40	20/40	20/40	20/40	20/40	25/40	25/40
	PN		25/16	25/16	25/16	25/16	25/16	25/16	25/16
Natural gas connection			1"G	1"G	1 ½"G	2"G	2"G	2"G	2"G
Feed water inlet			1"G	1"G	1"G	1"G	1"G	1"G	1 ½"G
Total volume	l		208	208	370	620/850	620/850	1100	2400
Pipes diameter	mm		60.3	60.3	60.3	60.3/50.8	60.3/50.8	50.8	50.8
Heating surface	m ²		6	6	8.8	14	14	18	32
Empty weight	Kg		600	750	900	1100	1100	2200	2800

THERMAL OIL HEATER - TOH200 to TOH6000

Dimensions of flash coil Thermal Oil Heater TOH200-T6000

Vertical Design

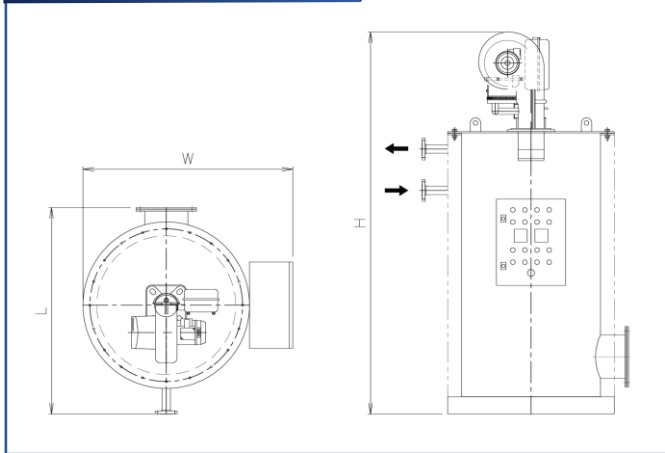

Horizontal Design

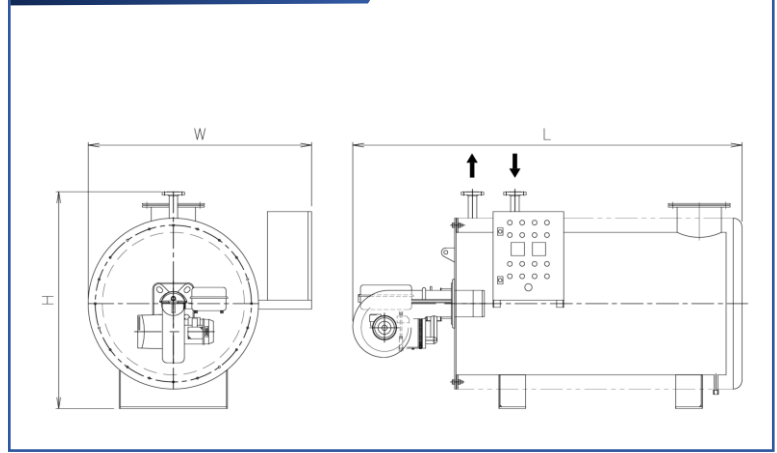

OVERALL DIMENSIONS AND CONNECTIONS OF THERMAL OIL HEATER IDM200-6000

MODEL-TOH			200	400	600	800	1000	2000	3000	4000	5000	6000
VERTICAL VERSION DIMENSIONS												
L	Length	mm	1200	1450	1590							
W	Width	mm	970	1390	1550							
H	Height	mm	2200	2550	3100							
HORIZONTAL VERSION DIMENSIONS												
L	Length	mm	2200	2450	3000	3570	3950	5100	6500	6750	6940	7100
W	Width	mm	970	1390	1550	1830	1940	2690	2900	3050	3120	3260
H	Height	mm	1250	1460	1690	1950	2250	2750	2850	3000	3180	3390
GENERAL TECHNICAL DATA												
Thermal Capacity	Mcal/h		200	400	600	800	1000	2000	3000	4000	5000	6000
Stack conn.	mm		250	250	290	320	320	385	385	485	485	485
Oil Inlet/Outlet	DN		40	40	50	50	80	100	100	125	150	150
	PN		16	16	16	16	16	16	16	16	16	16
Natural gas conn.	Ø		1" G	1½" G	2" G	2" G	2" G	2 ½" G	2 ½" G	3 ½" G	4 ½" G	5 ½" G
Total volume	ltr		80	190	290	432	540	1200	1750	2300	3150	3870
Pipes diameter	mm		48.3	48.3	60.3	60.3	60.3	76.1	76.1	76.1	88.9	88.9
Empty weight	Kg		750	900	1100	2200	2800	3400	4300	4300	4300	4300

BURNER CATALOG

Gas Fuel



Light Oil Fuel



Heavy Oil Fuel



Dual Fuel Gas/Oil

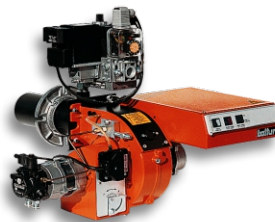

Merek Burner

